

P	Dimensions			
	A	B	C	D
02P	1.25	2.72	5.72	
03P	2.50	3.97	6.97	
04P	3.75	5.22	8.22	2.50
05P	5.00	6.47	9.47	3.75
06P	6.25	7.72	10.72	5.00
07P	7.50	8.97	11.97	6.25
08P	8.75	10.22	13.22	7.50
09P	10.00	11.47	14.47	8.75
10P	11.25	12.72	15.72	10.00
11P	12.50	13.97	16.97	11.25
12P	13.75	15.22	18.22	12.50
14P	16.25	17.72	20.72	15.00
15P	17.50	18.97	21.97	16.25
16P	18.75	20.22	23.22	17.50
20P	23.75	25.22	28.22	22.50
30P	36.25	37.72	40.72	22.50

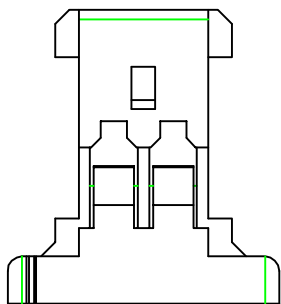

2P

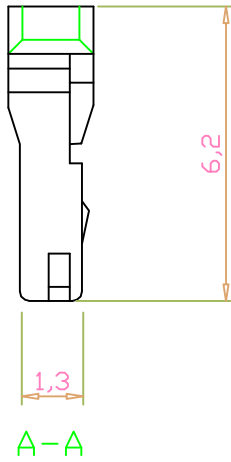
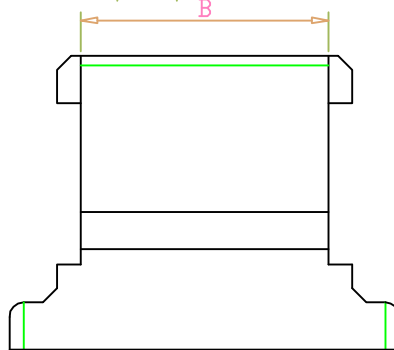
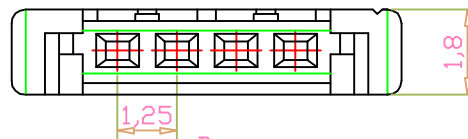
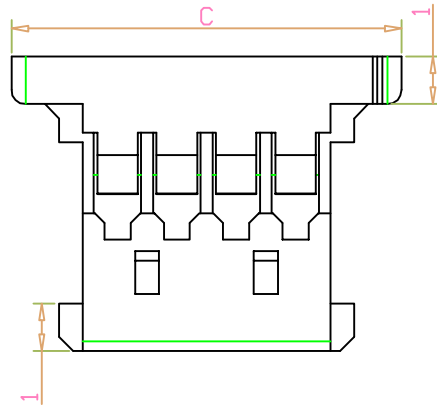
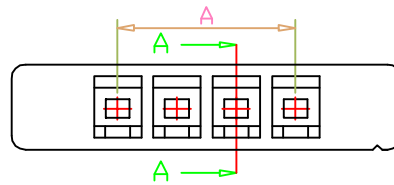
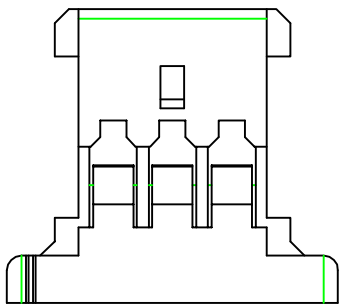

3P

LHF 东莞市连海电子有限公司
DONG GUAN LIAN HAI ELECTRONICS CO.LTD

DRAW NO.	DATE	MODEL NO	DRAW NAME
DESIGN		P/N NO:	MOX1.25 超薄HSG -NP
CHECK	周涛	A1254-H-NP	
REVIEW	刘丽娜	REV C	SCALE 1:1
		UNIT: mm	SHEET: 1 OF 1

DIM	TOL	DIM	TOL
X.		X.*	
X.X	±0.15	X.X*	±0.2*
X.XX	±0.10	X.XX*	±0.1*
X.XXX	±0.05	X.XXX*	±0.05*

6

5

4

3

2

1

F

F

E

E

D

D

C

C

B

B

A

A

技术参数: SPECIFICATIONS

适用线规: AWG#28~#32

Applicable wire: AWG#28~#32

额定电压: 250V DC/AC (有效值)

Voltage rating: 250V DC/AC (rms)

额定电流: 2.5-1.0A

Current rating: 2.5-1.0A

耐压值: 800V AC(有效值)

Withstand voltage: 800V AC(rms)

工作温度: -25℃~+85℃

Working Temperature: -25℃+85℃

绝缘电阻: ≥1000MΩ

Insulation resistance: ≥1000MΩ

接触电阻: ≤0.02Ω

Contact resistance: ≤0.02Ω

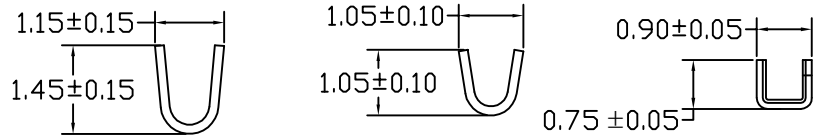
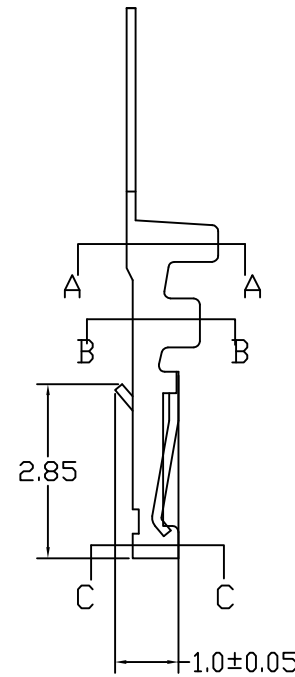
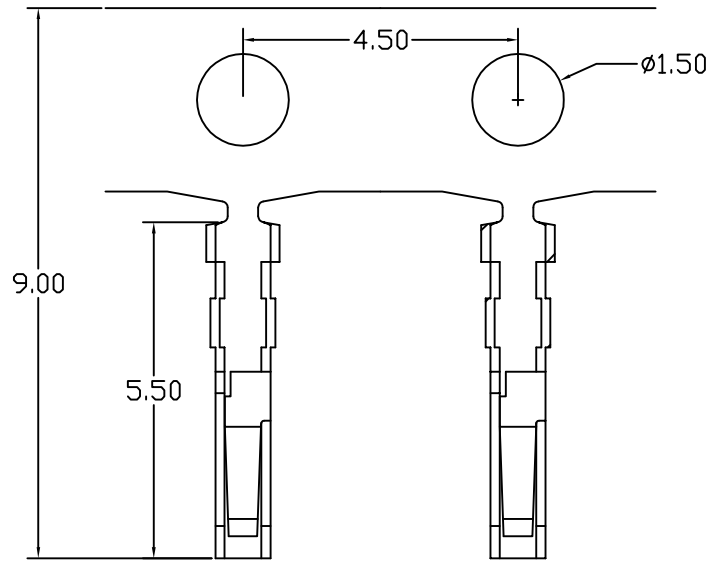

A-A SECTION B-B SECTION C-C SECTION

LHF 东莞市连海电子有限公司		A1254-T MOX1.25超薄端子	
DONG GUAN LIAN HAI ELECTRONICS CO.,LTD		材料:	0.15 磷铜
第一次修改		设计:	周涛
第二次修改		单位:	mm
第三次修改		绘图:	周涛
公差:	.x ±0.15 .xx ±0.05	包装规格:	20k / 卷
比例:		校对:	周涛
		审核:	刘丽娜
		批准:	刘丽娜

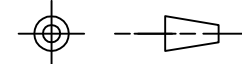

6

5

4

3

2

1

Poles	DIM.A	DIM.B
2P	1.25	7.65
3P	2.50	8.90
4P	3.75	10.15
5P	5.00	11.40
6P	6.25	12.65
7P	7.50	13.90
8P	8.75	15.15
9P	10.00	16.40
10P	11.25	17.65
12P	13.75	20.15
13P	15.00	21.40
14P	16.25	22.65
15P	17.50	23.90
16P	18.75	25.15
18P	21.25	27.65
20P	23.75	30.15
22P	26.25	32.65
24P	28.75	35.15
26P	31.25	37.65
28P	33.75	40.15
30P	36.25	42.65

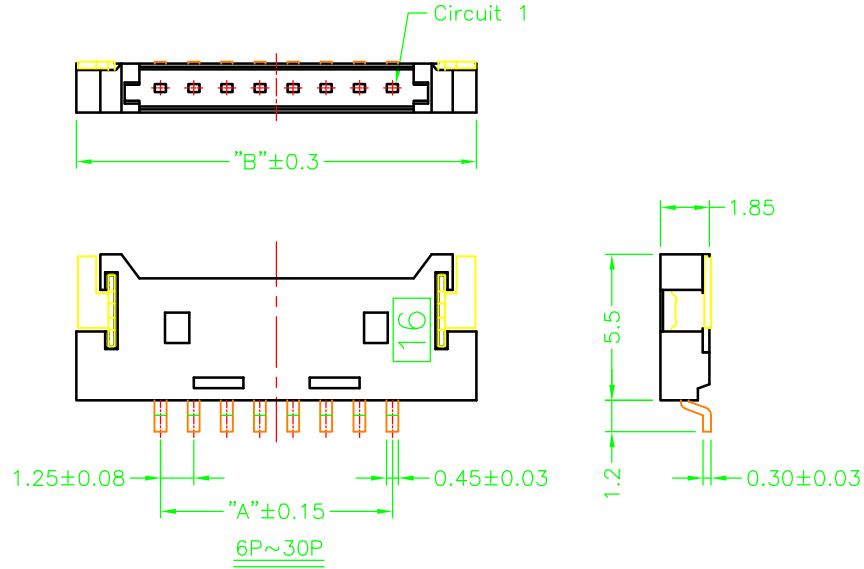

■ 技术参数 SPECIFICATIONS

- ◆ 适用线规: AWG.#28~#30
Applicable Wire: AWG.#28~#30
- ◆ 额定电压: 125V DC/AC(rms)
Rated voltage: 125V DC/AC(rms)
- ◆ 额定电流: 1A (max.)
Rated Current: 1A (max.)
- ◆ 耐压值: 250V AC/minute
Withstand voltage: 250V AC/min.
- ◆ 工作温度: -40°C ~ +85°C
Working Temp: -40°C ~ +85°C
- ◆ 绝缘电阻: ≥500 MΩ
Insulation resistance: ≥500 MΩ
- ◆ 接触电阻: ≤20 mΩ
Contact resistance: ≤20 mΩ

■ 材料 MATERIAL

- ◆ 绝缘体: 尼龙9T, UL94-V0
Insulator: PA9T, UL94-V0
- ◆ 接触针: 磷铜
Contact PIN: Phosphor bronze
- ◆ 焊片: 磷铜
Solder tab: Phosphor bronze

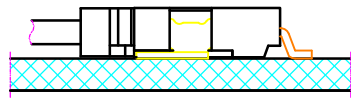

Assembly Layout

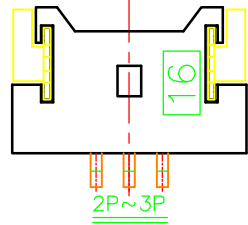

2P~3P

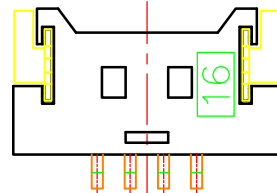

4P~5P

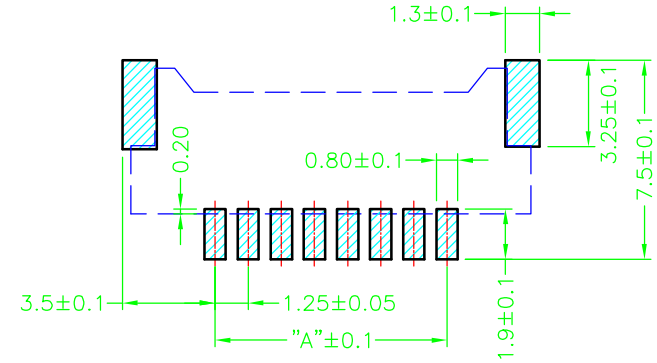

P.C.B LAYOUT

LHF 东莞市连海电子有限公司
DONG GUAN LIAN HAI ELECTRONICS CO.,LTD

DRAW NO. DESIGN:	DATE	MODEL NO P/N NO: A1254-WR-S-NP	DRAW NAME MOX1.25 超薄卧贴-NP
CHECK:	周涛	REV C	SCALE 1:1
REVIEW:	刘丽娜	UNIT: mm	SHEET: 1 OF 1

DIM	TOL	DIM	TOL
X.	/	X.*	/
X.X	±0.15	X.X*	±2*
X.XX	±0.10	X.XX*	±1*
X.XXX	±0.05	X.XXX*	/