

品名:DF14
 材料規格:尼龍66
 顏色:灰色
 料号:A1253-H-NP

NOTE:

1. 標注公差尺寸為重點檢驗尺寸。
2. 一般公差:SIZE $\pm 0.050\text{mm}$; ANGLE: $\pm 1^\circ$ 。
3. 無缺料.無堵孔,無變形現象。

LHF 东莞市连海电子有限公司
 DONG GUAN LIAN HAI ELECTRONICS CO.,LTD

DRAW NO.	DATE	MODEL NO	DRAW NAME
DESIGN:		P/N NO:	DF14 HSG-NP
CHECK:	周涛	A1253-H-NP	
REVIEW:	刘丽娜	REV C	SCALE 1:1
		UNIT: mm	SHEET: 1 OF 1

DIM	TOL	DIM	TOL
X.	/	X.*	/
X.X	± 0.15	X.X*	$\pm 2^\circ$
X.XX	± 0.10	X.XX*	$\pm 1^\circ$
X.XXX	± 0.05	X.XXX*	/

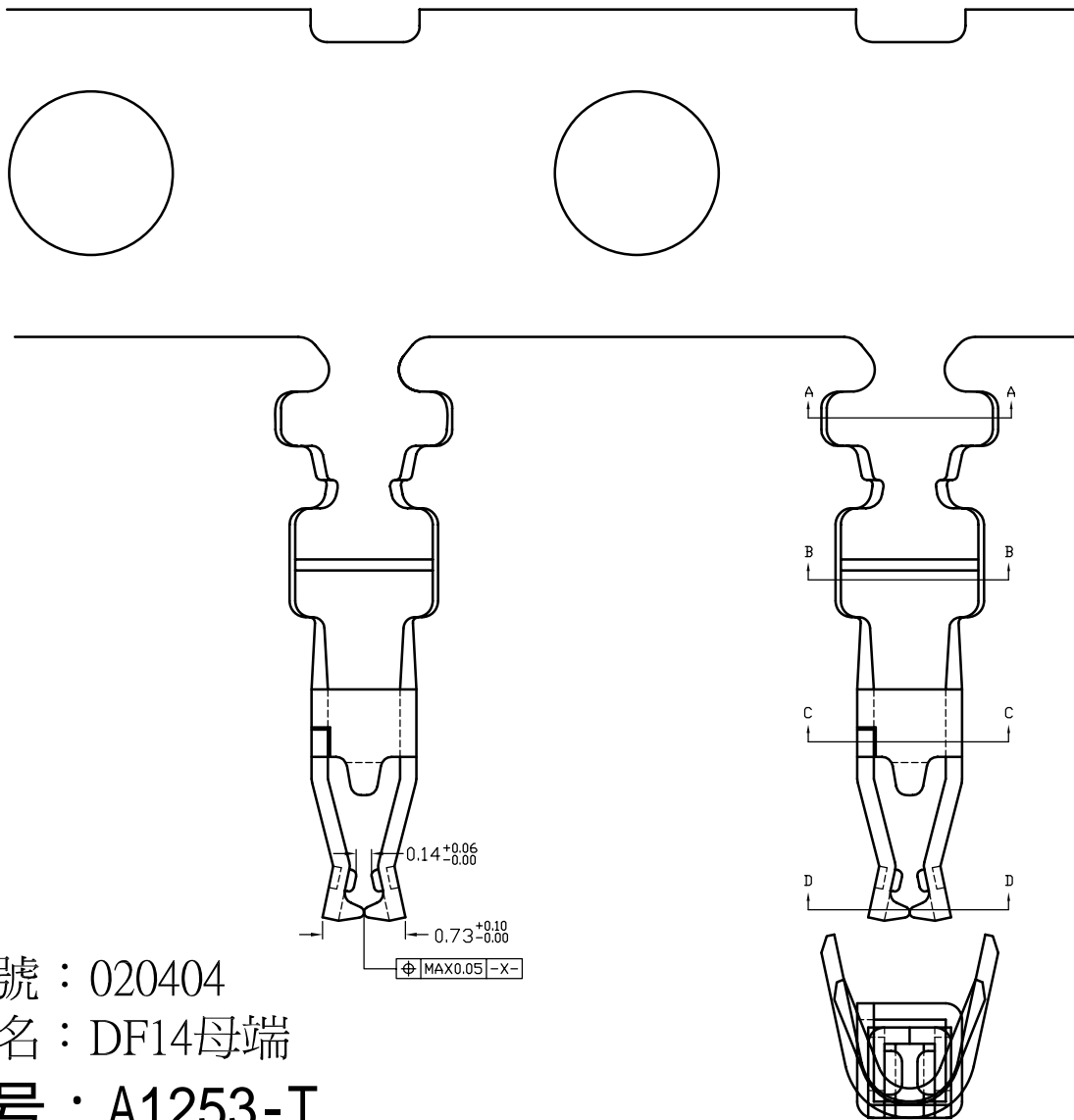

圖號：020404

品名：DF14母端

料号：A1253-T

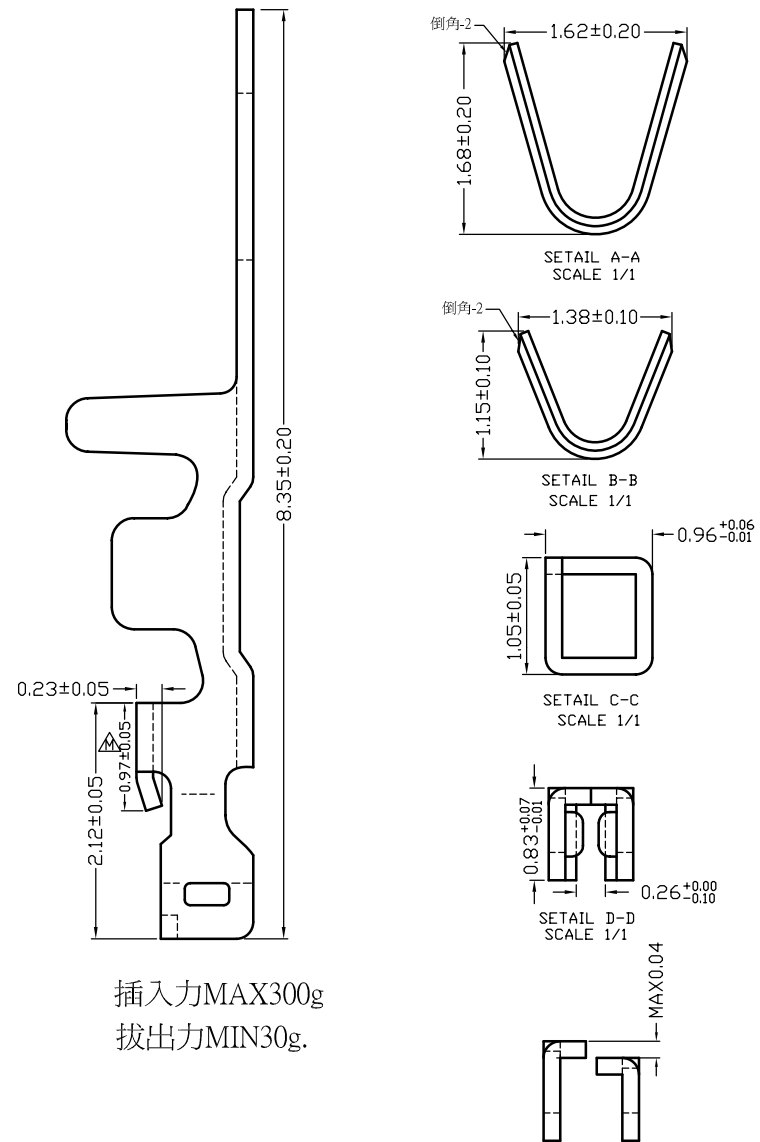

插入力MAX300g
拔出力MIN30g.

LHF 东莞市连海电子有限公司
DONG GUAN LIAN HAI ELECTRONICS CO.LTD

DRAW NO.	DATE	MODEL NO	DRAW NAME
DESIGN:		P/N NO:	DF14 镀锡端子
CHECK:	周涛	A1253-T	
REVIEW:	刘丽娜	REV C	SCALE 1:1
		UNIT: mm	SHEET: 1 OF 1

DIM	TOL	DIM	TOL
X.		X.*	
X.X	±0.15	X.X*	±2°
X.XX	±0.10	X.XX*	±1°
X.XXX	±0.05	X.XXX*	/

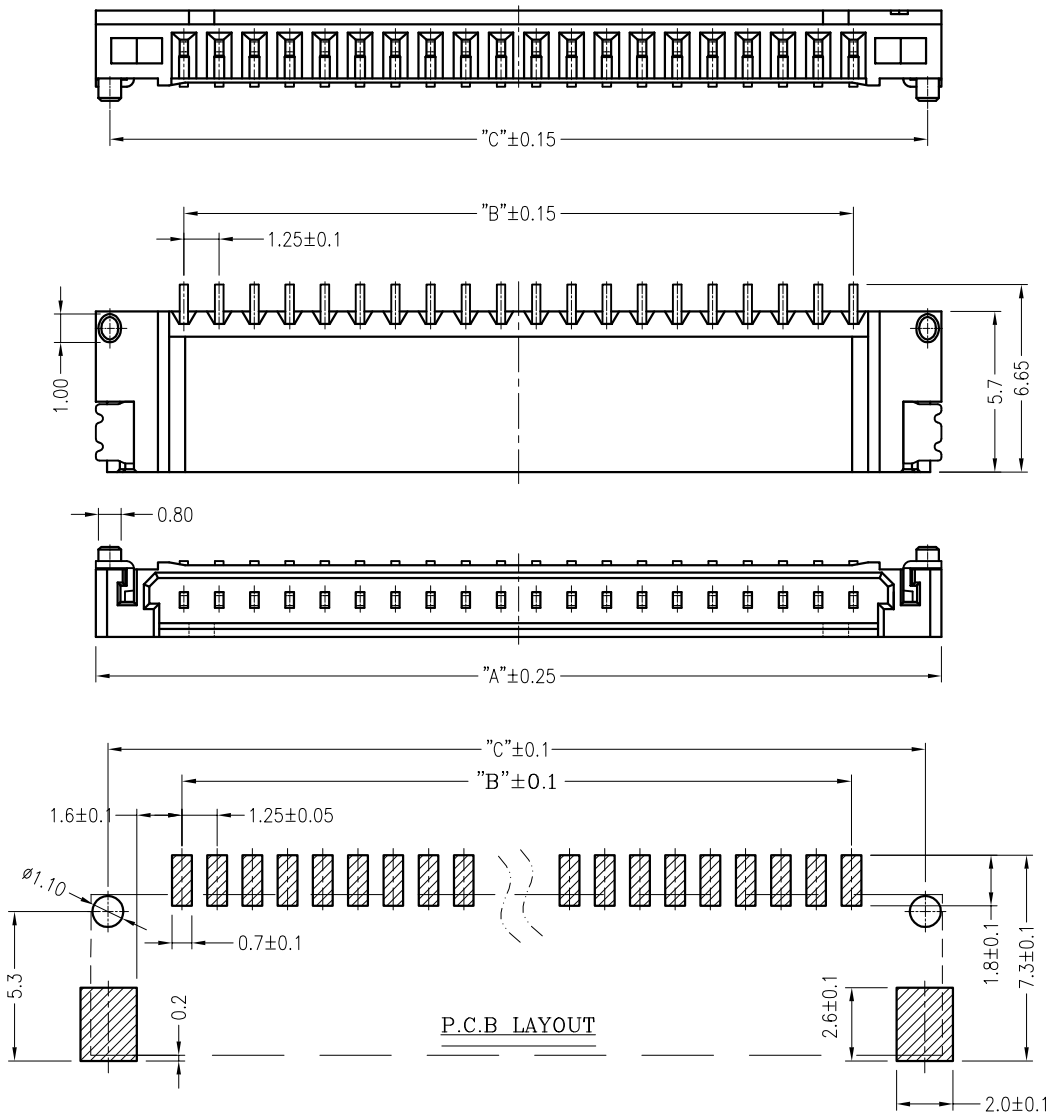

■ 技术参数 SPECIFICATIONS

- ◆ 适用线规: AWG#32~#28
Applicable Wire: AWG#32~#28
- ◆ 额定电压: 150V DC,AC(rms)
Rated voltage: 150V DC,AC(rms)
- ◆ 额定电流: 1A (AWG #28)
Rated Current: 1A (AWG #28)
- ◆ 耐压值: 500V AC/minute
Withstand voltage: 500V AC/min.
- ◆ 工作温度: -25°C ~ +85°C
Working Temp : -25°C ~ +85°C
- ◆ 绝缘电阻: ≥500 MΩ
Insulation resistance: ≥500 MΩ
- ◆ 接触电阻: ≤30 mΩ
Contact resistance: ≤30 mΩ

■ 材料 MATERIAL

- ◆ 绝缘体: 尼龙9T, UL94-V0
Insulator: Nylon9T, UL94-V0
- ◆ 接触针: 磷铜
Contact PIN: Phosphor bronze
- ◆ 焊片: 磷铜
Solder tab: Phosphor bronze

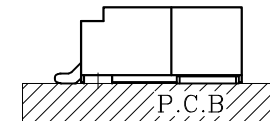

Poles	DIM.A	DIM.B	DIM.C
20P	30.00	23.75	29.0
30P	42.50	36.25	41.5

LHF 东莞市连海电子有限公司
DONG GUAN LIAN HAI ELECTRONICS CO.LTD

DRAW NO.	DATE	MODEL NO	DRAW NAME
DESIGN:		P/N NO:	DF14 卧贴-NP (带柱)
CHECK:	周涛	A1253-WR-S-1*NP	
REVIEW:	刘丽娜	REV C	SCALE 1:1

DIM	TOL	DIM	TOL
X.	/	X.*	/
X.X	±0.15	X.X*	±2*
X.XX	±0.10	X.XX*	±1*
X.XXX	±0.05	X.XXX*	/

UNIT: mm SHEET: 1 OF 1

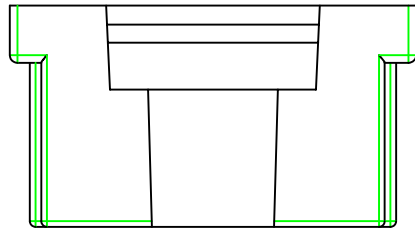

02P~10P

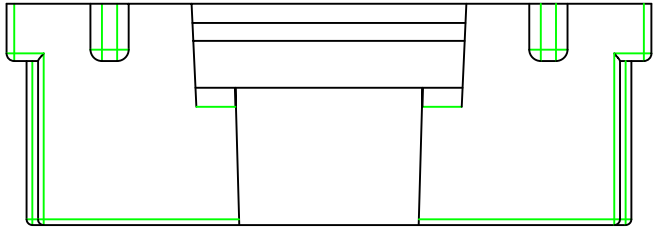

11P~30P

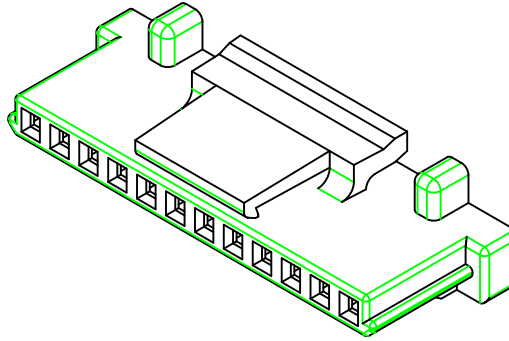

SPECIFICATIONS

Current Rating: 1A AC,DC
 Voltage Rating: 150V AC,DC
 Temperature Range: -25°C ~ +85°C
 Contact Resistance: 30mΩ Max.
 Insulation Resistance: 500MΩ Min.
 Withstanding Voltage: 500V AC/minute
 Material: Nylon 66,UL94V-0
 Color: Natural(White)

Ordering Information & Dimensions

PART NO.	Dimensions		
	A	B	C
A1253HA-02P	1.25	4.40	2.75
A1253HA-03P	2.50	5.65	4.00
A1253HA-04P	3.75	6.90	5.25
A1253HA-05P	5.00	8.15	6.50
A1253HA-06P	6.25	9.40	7.75
A1253HA-07P	7.50	10.65	9.00
A1253HA-08P	8.75	11.90	10.25
A1253HA-09P	10.00	13.15	11.50
A1253HA-10P	11.25	14.40	12.75
A1253HA-11P	12.50	15.65	14.00
A1253HA-12P	13.75	16.90	15.25
A1253HA-13P	15.00	18.15	16.50
A1253HA-14P	16.25	19.40	17.75
A1253HA-15P	17.50	20.65	19.00
A1253HA-20P	23.75	26.90	25.25
A1253HA-25P	30.00	33.15	31.50
A1253HA-30P	36.25	39.40	37.75

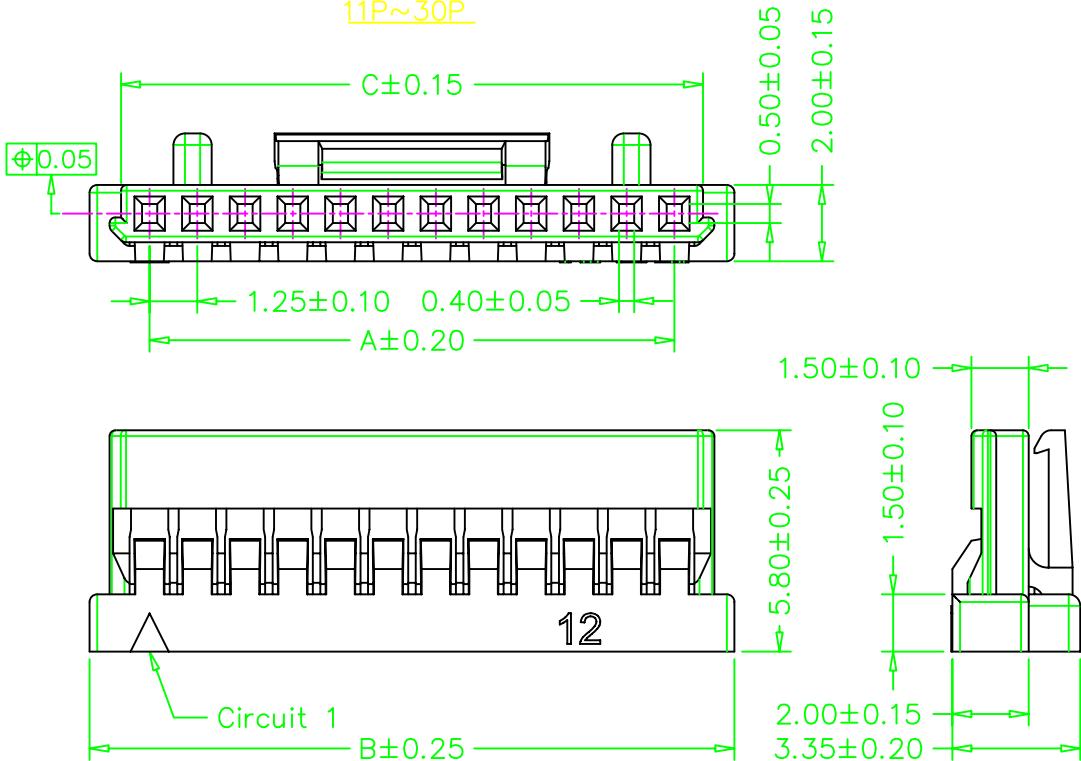

DIM	TOL	DIM	TOL
X.	/	X.*	/
X.X	±0.15	X.X*	±2*
X.XX	±0.10	X.XX*	±1*
X.XXX	±0.05	X.XXX*	/

LHF 东莞市连海电子有限公司 DONG GUAN LIAN HAI ELECTRONICS CO.LTD			
DRAW NO.	DATE	MODEL NO P/N NO.	DRAW NAME
DESIGN:		A1253-HA-NP	DF14 HSG-NP
CHECK	周涛		
REVIEW:		REV C	SCALE 1:1
		UNIT: mm	SHEET: 1 OF 1

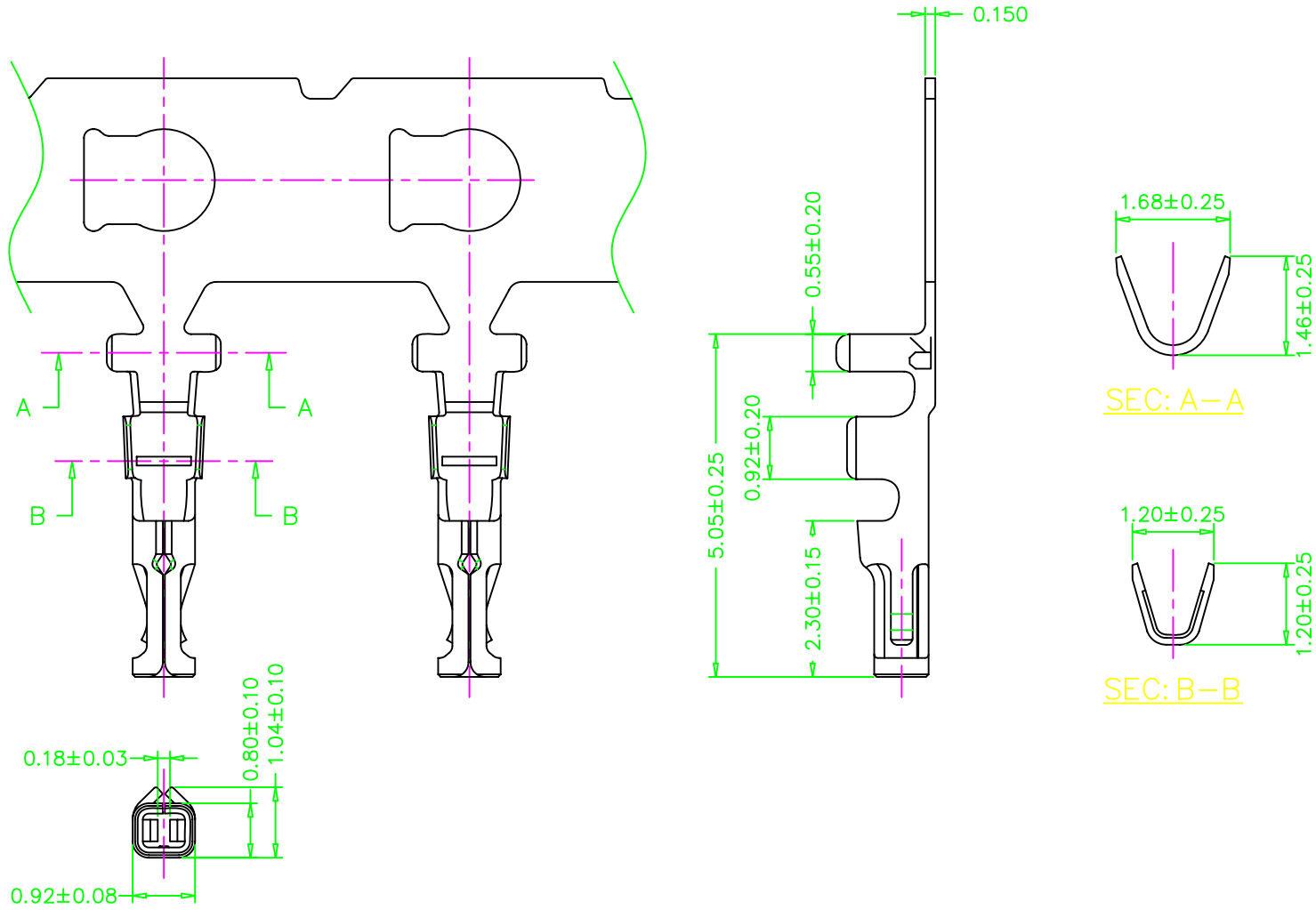

Ordering Information & Specifications

Part No	Wire Range	Insulation O.D.	Material	Finish	Qty/reel
A1253-GPE-A	AWG#28-#32	0.90mm(max)	Phosphor Bronze	Gold-plated	15,000pcs
A1253-TPE-A	AWG#28-#32	0.90mm(max)	Phosphor Bronze	Tin-plated	15,000pcs

Note:E-Stamping before Gold-plated or Tin-plated

DIM	TOL	DIM	TOL
X	/	X*	/
X.X	±0.15	X.X*	±2*
X.XX	±0.10	X.XX*	±1*
X.XXX	±0.05	X.XXX*	/

LHF 东莞市连海电子有限公司 DONG GUAN LIAN HAI ELECTRONICS CO.LTD			
DRAW NO.	DATE	MODEL NO	DRAW NAME
DESIGN:		P/N NO: A1253-TA	DF14 带扣端子
CHECK:	周涛		
REVIEW:		REV C	SCALE 1:1
		UNIT: mm	SHEET: 1 OF 1

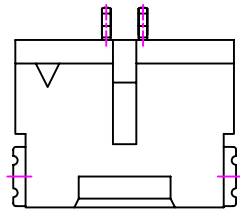

02P

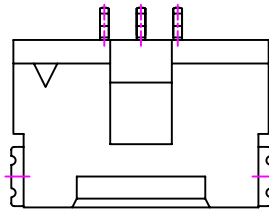

03P

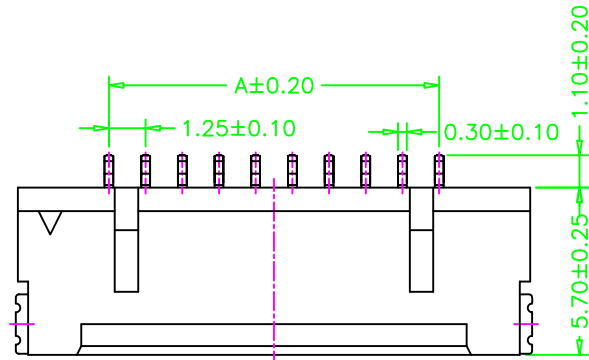
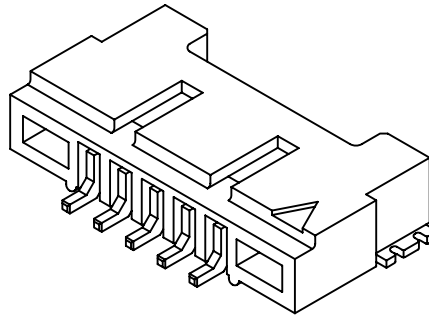

04P~30P

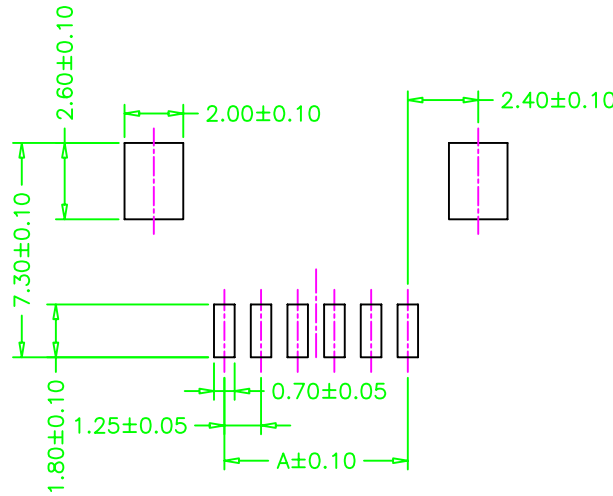

P.C.B. LAYOUT

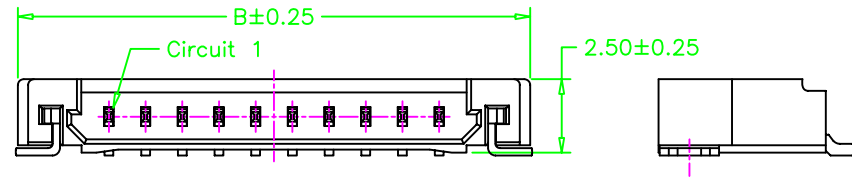

SPECIFICATIONS
 Current Rating: 1A AC,DC
 Voltage Rating: 150V AC,DC
 Temperature Range: -25°C ~ +85°C
 Contact Resistance: 30mΩ Max.
 Insulation Resistance: 500MΩ Min.
 Withstanding Voltage: 500V AC/minute
 Pin Material: Brass/Tin-plated
 Solder Tabs: Brass/Tin-plated
 Material: Nylon 6T,UL94V-0
 Color: Natural(Beige)

Ordering Information & Dimensions

PART NO.	Dimensions	
	A	B
A1253WR-S-02P	1.25	7.45
A1253WR-S-03P	2.50	8.70
A1253WR-S-04P	3.75	9.95
A1253WR-S-05P	5.00	11.20
A1253WR-S-06P	6.25	12.45
A1253WR-S-07P	7.50	13.70
A1253WR-S-08P	8.75	14.95
A1253WR-S-09P	10.00	16.20
A1253WR-S-10P	11.25	17.45
A1253WR-S-11P	12.50	18.70
A1253WR-S-12P	13.75	19.95
A1253WR-S-13P	15.00	21.20
A1253WR-S-14P	16.25	22.45
A1253WR-S-15P	17.50	23.70
A1253WR-S-20P	23.75	29.95
A1253WR-S-21P	25.00	31.20
A1253WR-S-25P	30.00	36.20
A1253WR-S-30P	36.25	42.45

LHF 东莞市连海电子有限公司
 DONG GUAN LIAN HAI ELECTRONICS CO.LTD

DRAW NO.	DATE	MODEL NO	DRAW NAME
DESIGN:		P/N NO:	
CHECK:	周涛	A1253-WR-S-NP	DF14 卧贴-NP
REVIEW:		REV C	SCALE 1:1
		UNIT: mm	SHEET: 1 OF 1

DIM	TOL	DIM	TOL
X	/	X*	/
X.X	±0.15	X.X*	±2°
X.XX	±0.10	X.XX*	±1°
X.XXX	±0.05	X.XXX*	/

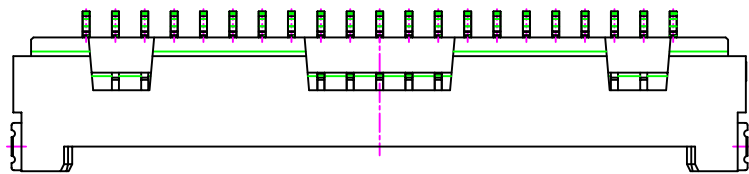

21P~30P
SCALE 0.8:1

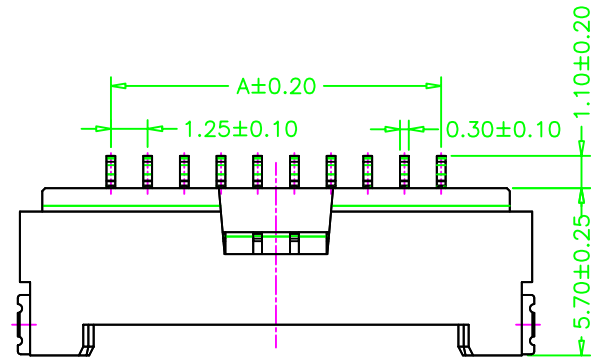
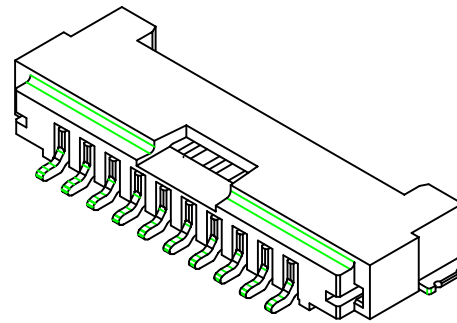

02P~20P

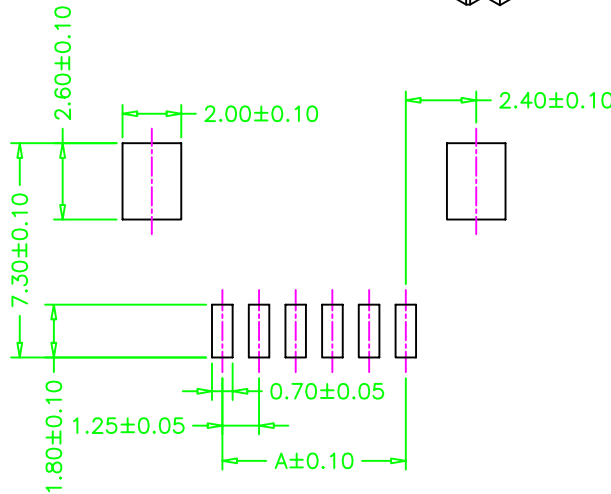

P.C.B. LAYOUT

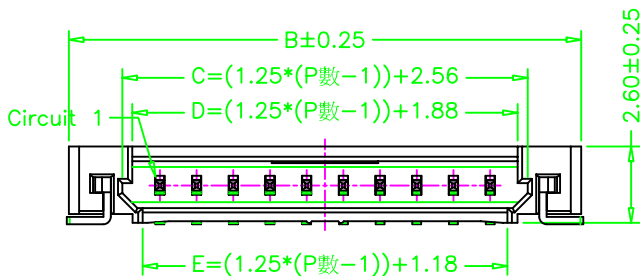

SPECIFICATIONS

Current Rating: 1A AC,DC
Voltage Rating: 150V AC,DC
Temperature Range: -25°C ~ +85°C
Contact Resistance: 30mΩ Max.
Insulation Resistance: 500MΩ Min.
Withstanding Voltage: 500V AC/minute
Pin Material: Brass/Tin-plated
Solder Tabs: Brass/Tin-plated
Material: Nylon 6T,UL94V-0
Color: Natural(Beige)

Ordering Information & Dimensions

PART NO.	Dimensions	
	A	B
A1253WRA-S-02P	1.25	7.45
A1253WRA-S-03P	2.50	8.70
A1253WRA-S-04P	3.75	9.95
A1253WRA-S-05P	5.00	11.20
A1253WRA-S-06P	6.25	12.45
A1253WRA-S-07P	7.50	13.70
A1253WRA-S-08P	8.75	14.95
A1253WRA-S-09P	10.00	16.20
A1253WRA-S-10P	11.25	17.45
A1253WRA-S-11P	12.50	18.70
A1253WRA-S-12P	13.75	19.95
A1253WRA-S-13P	15.00	21.20
A1253WRA-S-14P	16.25	22.45
A1253WRA-S-15P	17.50	23.70
A1253WRA-S-20P	23.75	29.95
A1253WRA-S-25P	30.00	36.20
A1253WRA-S-30P	36.25	42.45

LHF 东莞市连海电子有限公司
DONG GUAN LIAN HAI ELECTRONICS CO. LTD

DRAW NO.	DATE	MODEL NO	DRAW NAME
DESIGN:		P/N NO:	
CHECK:	周涛	A1253-WRA-S-NP	DF14 带扣针座
REVIEW:		REV C	SCALE 1:1
		UNIT: mm	SHEET: 1 OF 1

DIM	TOL	DIM	TOL
X.	/	X.*	/
X.X	±0.15	X.X*	±2°
X.XX	±0.10	X.XX*	±1°
X.XXX	±0.05	X.XXX*	/