

LHF 东莞市连海电子有限公司

DONG GUAN LIAN HAI ELECTRONICS CO.LTD

产品编号

A2100-H

产品名称

JAE-2.0mm

MATERIAL: NYLON 66 UL94V-0

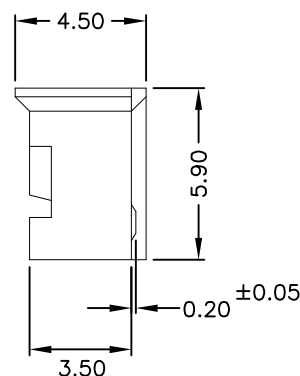
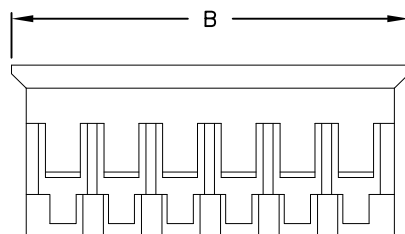
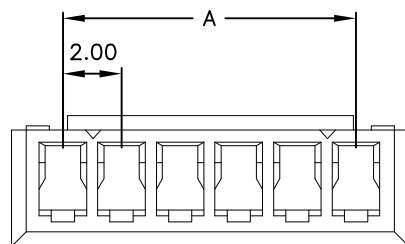

Dimensional & Ordering Information:

Circuits	Part No	Dimension(mm)		PCS/BAG
		A	B	
2	A2100-H-02P	2.0	5.60	1,000
3	A2100-H-03P	4.0	7.60	1,000
4	A2100-H-04P	6.0	9.60	1,000
5	A2100-H-05P	8.0	11.60	1,000
6	A2100-H-06P	10.0	13.60	1,000
7	A2100-H-07P	12.0	15.60	1,000
8	A2100-H-08P	14.0	17.60	1,000
9	A2100-H-09P	16.0	19.60	1,000
10	A2100-H-10P	18.0	21.60	1,000
11	A2100-H-11P	20.0	23.60	1,000
12	A2100-H-12P	22.0	25.60	1,000
13	A2100-H-13P	24.0	27.60	1,000
14	A2100-H-14P	26.0	29.60	1,000
15	A2100-H-15P	28.0	31.60	1,000
16	A2100-H-16P	30.0	33.60	1,000

Poles	2~16 Poles
Pitch between poles	2.0mm
Rated Voltage	250V AC,DC
Rated current	2A
Withstand Voltage	800V AC/minute
Insulation Resistance	1,000m Ω/min
Temperaure Range	-25~85°C
Applicable Wire	AWG#22~#30

REV	ECN NO.	UNIT	TOLERANCE	PROJECTION	DRAWING	CHECK	APPROVAL
A	NEW DRAWING	mm	*** ±0.08		周涛	周涛	周涛
B			** ±0.15				
			* ±0.25				

LHF 东莞市连海电子有限公司

DONG GUAN LIAN HAI ELECTRONICS CO.LTD

产品编号

A2100-WV

产品名称

JAE-2.0mm

MATERIAL: NYLON 66 UL94V-0

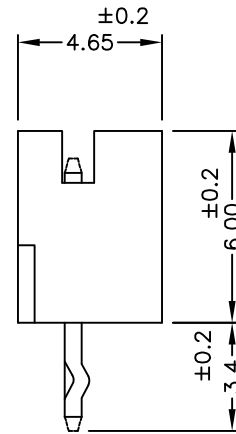
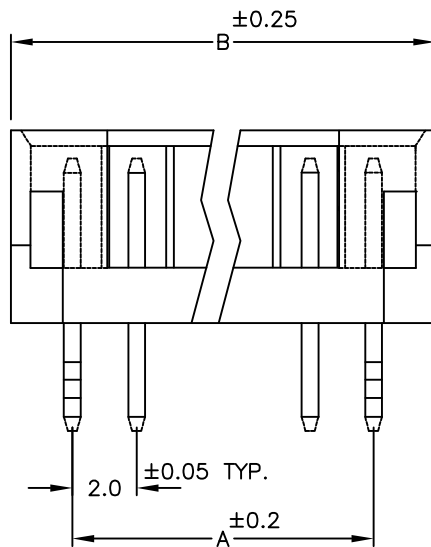

Circuits	Part No	Dimension (mm)		PCS/BAG
		A	B	
	180°			
2	A2100-WV-02P	2.0	6.0	1,000
3	A2100-WV-03P	4.0	8.0	1,000
4	A2100-WV-04P	6.0	10.0	1,000
5	A2100-WV-05P	8.0	12.0	1,000
6	A2100-WV-06P	10.0	14.0	1,000
7	A2100-WV-07P	12.0	16.0	1,000
8	A2100-WV-08P	14.0	18.0	1,000
9	A2100-WV-09P	16.0	20.0	1,000
10	A2100-WV-10P	18.0	22.0	1,000
11	A2100-WV-11P	20.0	24.0	1,000
12	A2100-WV-12P	22.0	26.0	1,000
13	A2100-WV-13P	24.0	28.0	1,000
14	A2100-WV-14P	26.0	30.0	1,000
15	A2100-WV-15P	28.0	32.0	1,000
16	A2100-WV-16P	30.0	34.0	1,000

Poles	2~16 Poles
Pitch between poles	2.0mm
Rated Voltage	250V AC,DC
Rated current	2A
Withstand Voltage	800V AC/minute
Insulation Resistance	1,000mΩ/min
Temperaure Range	-25~85°C

REV	ECN NO.	UNIT	TOLERANCE	PROJECTION	DRAWING	CHECK	APPROVAL
A	NEW DRAWING	mm	.*** ±0.08		周涛	周涛	周涛
B			.** ±0.15				
			.* ±0.25				

<h1 style="margin: 0;">东莞市连海电子有限公司</h1> <h2 style="margin: 0;">LHF DONG GUAN LIAN HAI ELECTRONICS CO.LTD</h2>	产品编号
	A2100-WR
	产品名称
	JAE-2.0mm

MATERIAL: NYLON 66 UL94V-0

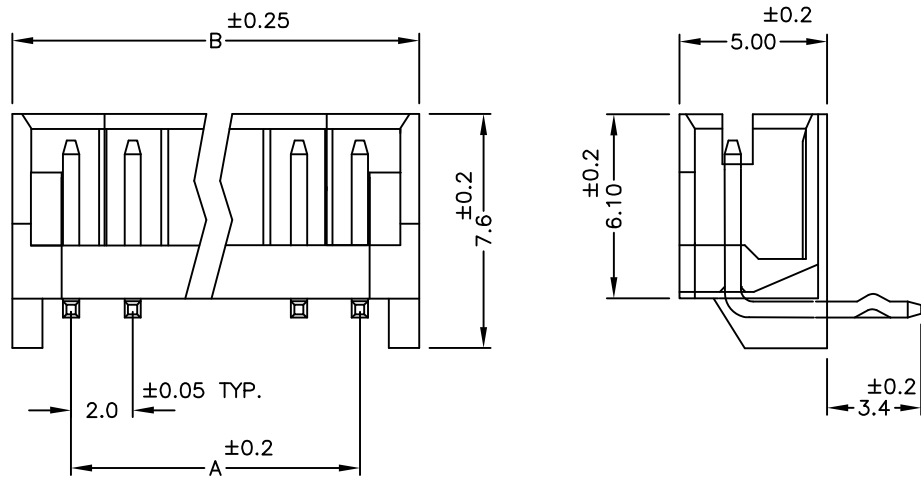

Circuits	Part No	Dimension (mm)		PCS/BAG
		A	B	
	180°			
2	A2100-WR-02P	2.0	6.0	1,000
3	A2100-WR-03P	4.0	8.0	1,000
4	A2100-WR-04P	6.0	10.0	1,000
5	A2100-WR-05P	8.0	12.0	1,000
6	A2100-WR-06P	10.0	14.0	1,000
7	A2100-WR-07P	12.0	16.0	1,000
8	A2100-WR-08P	14.0	18.0	1,000
9	A2100-WR-09P	16.0	20.0	1,000
10	A2100-WR-10P	18.0	22.0	1,000
11	A2100-WR-11P	20.0	24.0	1,000
12	A2100-WR-12P	22.0	26.0	1,000
13	A2100-WR-13P	24.0	28.0	1,000
14	A2100-WR-14P	26.0	30.0	1,000
15	A2100-WR-15P	28.0	32.0	1,000
16	A2100-WR-16P	30.0	34.0	1,000

Poles	2~16 Poles
Pitch between poles	2.0mm
Rated Voltage	250V AC,DC
Rated current	2A
Withstand Voltage	800V AC/minute
Insulation Resistance	1,000mΩ/min
Temperaure Range	-25~85°C

REV	ECN NO.	UNIT	TOLERANCE	PROJECTION	DRAWING	CHECK	APPROVAL
△A	NEW DRAWING	mm	.*** ±0.08		周涛	周涛	周涛
△B			.** ±0.15				
			.* ±0.25				

LHF 东莞市连海电子有限公司

DONG GUAN LIAN HAI ELECTRONICS CO.LTD

产品编号

A2100-T

产品名称

JAE-2.0mm

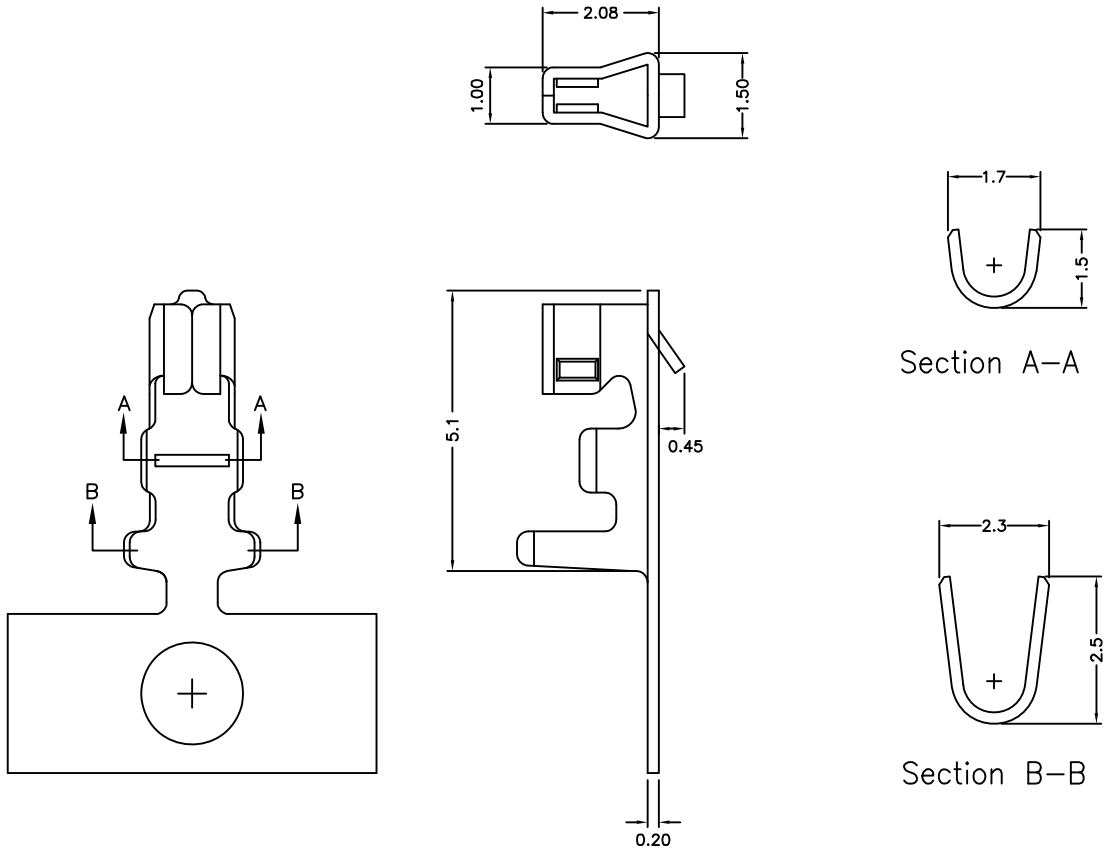

WIRE SIZE (AWG)	#24	#26	#28	#30
1 CRIMP WIDTH	1.3±0.1			
1 CRIMP HEIGHT	0.68-0.77	0.61-0.70	0.52-0.61	0.47-0.56
2 CRIMP WIDTH	1.50			
2 CRIMP HEIGHT	1.56	1.50	1.45	1.40
CRIMP STRRNGTH	3.0kgf (MIN)	1.8kgf (MIN)	1.1kgf (MIN)	0.6kgf (MIN)

1. CONDUCTOR (mm) 2. INSULATTON (mm)

Specifications & Ordering Information:

Part No	Wire Range	Material	Finish	Qty/reel
	AWG#22~#30	Phosphor bronze	Tin-Plated	10,000 PCS

REV	ECN NO.	UNIT	TOLERANCE	PROJECTION	DRAWING	CHECK	APPROVAL
△A	NEW DRAWING	mm	*** ±0.08		周涛	周涛	周涛
△B			** ±0.15				
			* ±0.25				