

SPECIFICATIONS

Current Rating: 3A AC,DC

Voltage Rating: 350V AC,DC

Temperature Range: -25°C ~ +85°C

Contact Resistance: 20mΩ Max.

Insulation Resistance: 1000MΩ Min.

Withstanding Voltage: 500V AC/minute

Material: Nylon 66,UL94V-0

Color: Natural(White)

Ordering Information & Dimensions

PART NO.	Dimensions	
	A	B
A1501H-02P	1.50	4.10
A1501H-03P	3.00	5.60
A1501H-04P	4.50	7.10
A1501H-05P	6.00	8.60
A1501H-06P	7.50	10.10
A1501H-07P	9.00	11.60
A1501H-08P	10.50	13.10
A1501H-09P	12.00	14.60
A1501H-10P	13.50	16.10
A1501H-11P	15.00	17.60
A1501H-12P	16.50	19.10
A1501H-13P	18.00	20.60
A1501H-14P	19.50	22.10
A1501H-15P	21.00	23.60

LHF 东莞市连海电子有限公司			
DONG GUAN LIAN HAI ELECTRONICS CO.LTD			
UNIT	SCALE	SHEET	TITLE:
mm		1 of 1	1.50mm PITCH HOUSING
DRAWN BY		APPROVED BY	
GENERAL TOLERANCE			DRAW NO.: A1501H-nP
X.X±0.25		ANGLE±	
X.XX±0.15		☺	
BO	NEW RELEASE	2006.04.13	X.XXX±0.05
REV.	DESCRIPTION	DATE	
			REV. B0

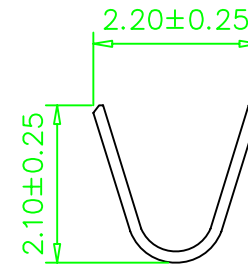
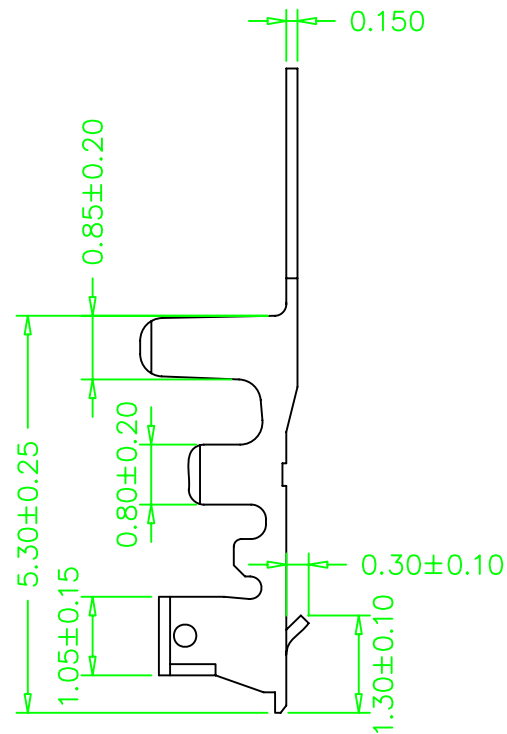
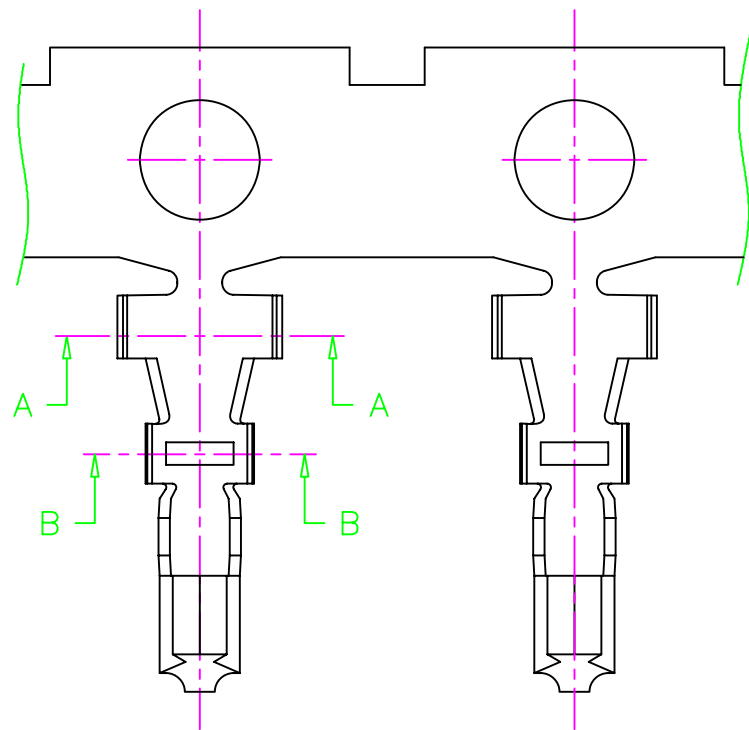

SEC: A-A

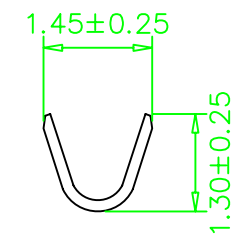

SEC: B-B

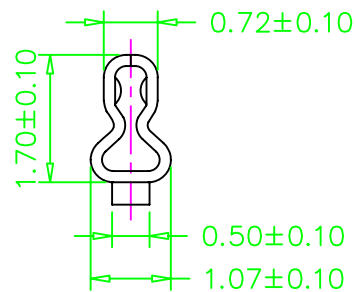

Ordering Information & Specifications

Part No	Wire Range	Insulation O.D.	Material	Finish	Qty/reel
A1501-TPE	AWG#24-#28	1.10mm(max)	Phosphor Bronze	Tin-plated	10,000pcs

Note: E-Stamping before Tin-plated

LHF 东莞市连海电子有限公司
DONG GUAN LIAN HAI ELECTRONICS CO.LTD

UNIT	SCALE	SHEET	TITLE:
mm		1 of 1	1.50mm PITCH CRIMP TERMINAL
DRAWN BY		APPROVED BY	
GENERAL TOLERANCE			DRAW NO.: A1501-T
B1	REVISE	2006.09.10	REV. B1
B0	NEW RELEASE	2006.04.13	
REV.	DESCRIPTION	DATE	

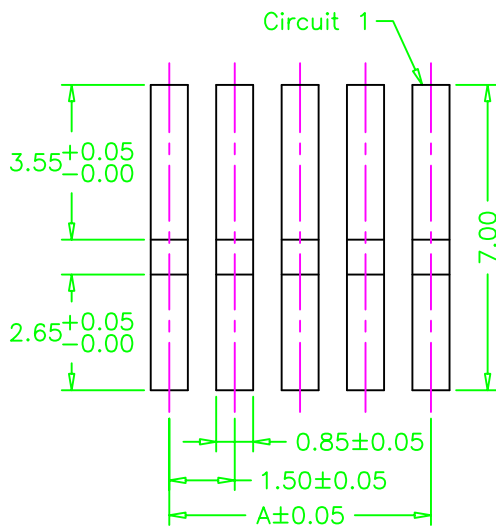
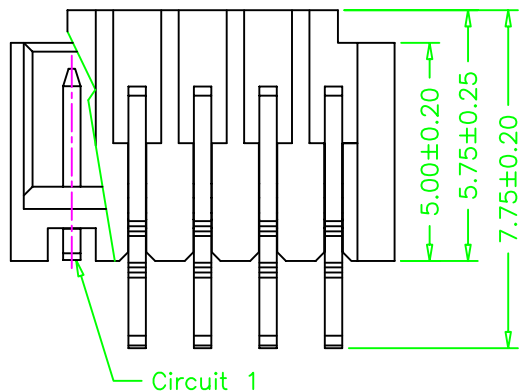
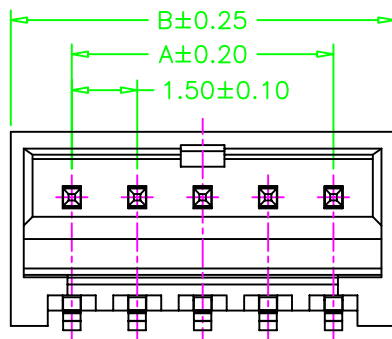
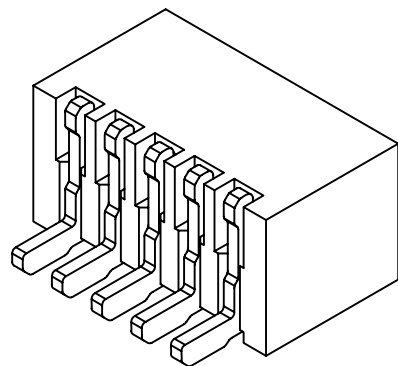

PCB LAYOUT

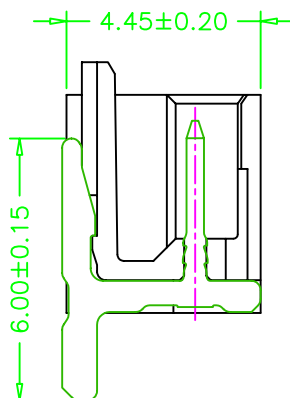

SPECIFICATIONS

Current Rating: 3A AC,DC
 Voltage Rating: 350V AC,DC
 Temperature Range: -25°C ~ +85°C
 Contact Resistance: 20mΩ Max.
 Insulation Resistance: 1000MΩ Min.
 Withstanding Voltage: 500V AC/minute
 Pin Material: Brass/Tin-plated
 Material: Nylon 6T,UL94V-0
 Color: Natural(Beige)

Ordering Information & Dimensions

PART NO.	Dimensions	
	A	B
A1501WR-S-02P	1.50	4.30
A1501WR-S-03P	3.00	5.80
A1501WR-S-04P	4.50	7.30
A1501WR-S-05P	6.00	8.80
A1501WR-S-06P	7.50	10.30
A1501WR-S-07P	9.00	11.80
A1501WR-S-08P	10.50	13.30
A1501WR-S-09P	12.00	14.80
A1501WR-S-10P	13.50	16.30
A1501WR-S-11P	15.00	17.80
A1501WR-S-12P	16.50	19.30
A1501WR-S-13P	18.00	20.80
A1501WR-S-14P	19.50	22.30
A1501WR-S-15P	21.00	23.80

LHP 东莞市连海电子有限公司
 DONG GUAN LIAN HAI ELECTRONICS CO.LTD

UNIT	SCALE	SHEET	TITLE:
mm		1 of 2	1.50mm PITCH 90°WAFER-SMT TYPE
DRAWN BY	APPROVED BY		
GENERAL TOLERANCE			
		ANGLE±	
BO	NEW RELEASE	2006.04.13	X.X±0.25
REV.	DESCRIPTION	DATE	X.XX±0.15
			X.XXX±0.05
DRAW NO.:			REV. B0
A1501WR-S-NP			

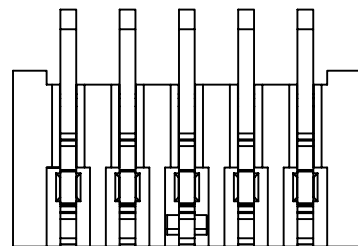
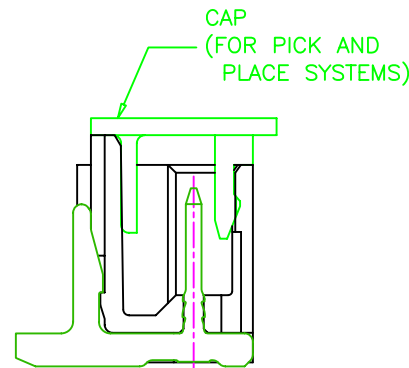
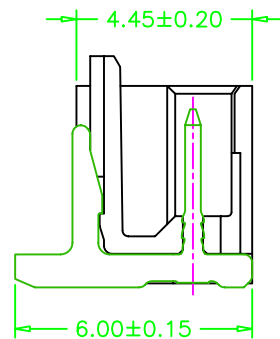
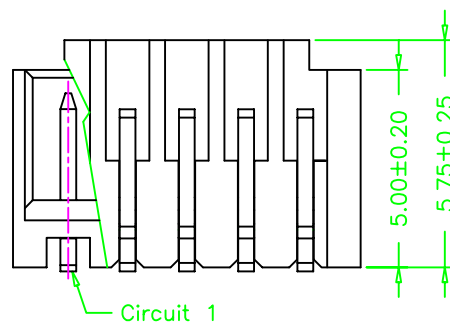
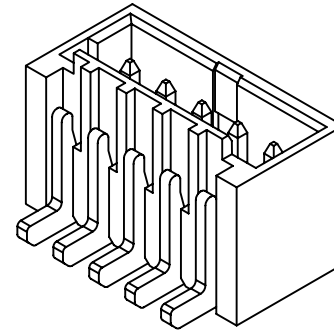
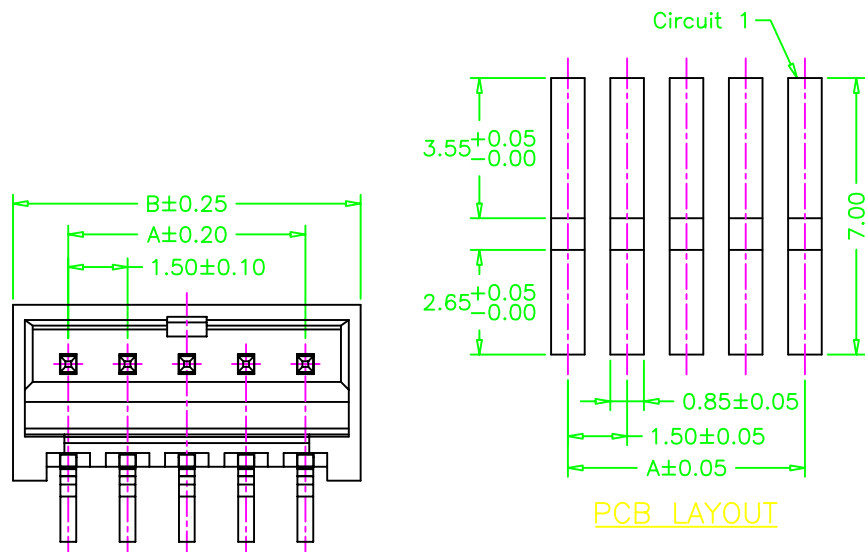

SPECIFICATIONS

Current Rating: 3A AC,DC

Voltage Rating: 350V AC,DC

Temperature Range: -25°C ~ +85°C

Contact Resistance: 20mΩ Max.

Insulation Resistance: 1000MΩ Min.

Withstanding Voltage: 500V AC/minute

Pin Material: Brass/Tin-plated

Material: Nylon 6T,UL94V-0

Color: Natural(Beige)

Ordering Information & Dimensions

PART NO.	Dimensions	
	A	B
A1501WV-S-02P	1.50	4.30
A1501WV-S-03P	3.00	5.80
A1501WV-S-04P	4.50	7.30
A1501WV-S-05P	6.00	8.80
A1501WV-S-06P	7.50	10.30
A1501WV-S-07P	9.00	11.80
A1501WV-S-08P	10.50	13.30
A1501WV-S-09P	12.00	14.80
A1501WV-S-10P	13.50	16.30
A1501WV-S-11P	15.00	17.80
A1501WV-S-12P	16.50	19.30
A1501WV-S-13P	18.00	20.80
A1501WV-S-14P	19.50	22.30
A1501WV-S-15P	21.00	23.80

				LHP 东莞市连海电子有限公司	
				DONG GUAN LIAN HAI ELECTRONICS CO.LTD	
UNIT	SCALE	SHEET	TITLE: 1.50mm PITCH 180°WAFER-SMT TYPE		
mm		1 of 2			
DRAWN BY		APPROVED BY		DRAW NO.:A1501-WV-S-NP	
GENERAL TOLERANCE			ANGLE±		
B1	REVISE	2006.09.10	X.X±0.25	DRAW NO.:A1501-WV-S-NP	
B0	NEW RELEASE	2006.04.13	X.XX±0.15		
REV.	DESCRIPTION	DATE	X.XXX±0.05	REV. B1	